

# LEADERSHIP CIRCLE MAT

The *Leadership Circle Mat* is the physical and visual representation of any of the Leadership Circle Assessment graphs scaled and created for group interaction.

Use the Leadership Circle Profile (LCP) Mat to help participants “get out of their heads” and into a physical experience that engenders interpretation and internalization of their LCP results on a higher level. Mat work increases the cognitive connections for participants, creating lasting memories and deeper understanding. The Mat facilitates interaction between individuals, groups, and teams and their respective profiles, often removing barriers to participation or tension that may otherwise occur.

## We have three Leadership Circle Mat options to use with your groups:

1. [FREE online Virtual Mat](#) on Google Slides
2. [Premium Virtual Mat](#) on Mural (may be co-branded)
3. [Physical Mats](#) in an array of sizes for in-person exercises

Plus check out our [Mat Exercises](#) and physical [Mat folding instructions](#).

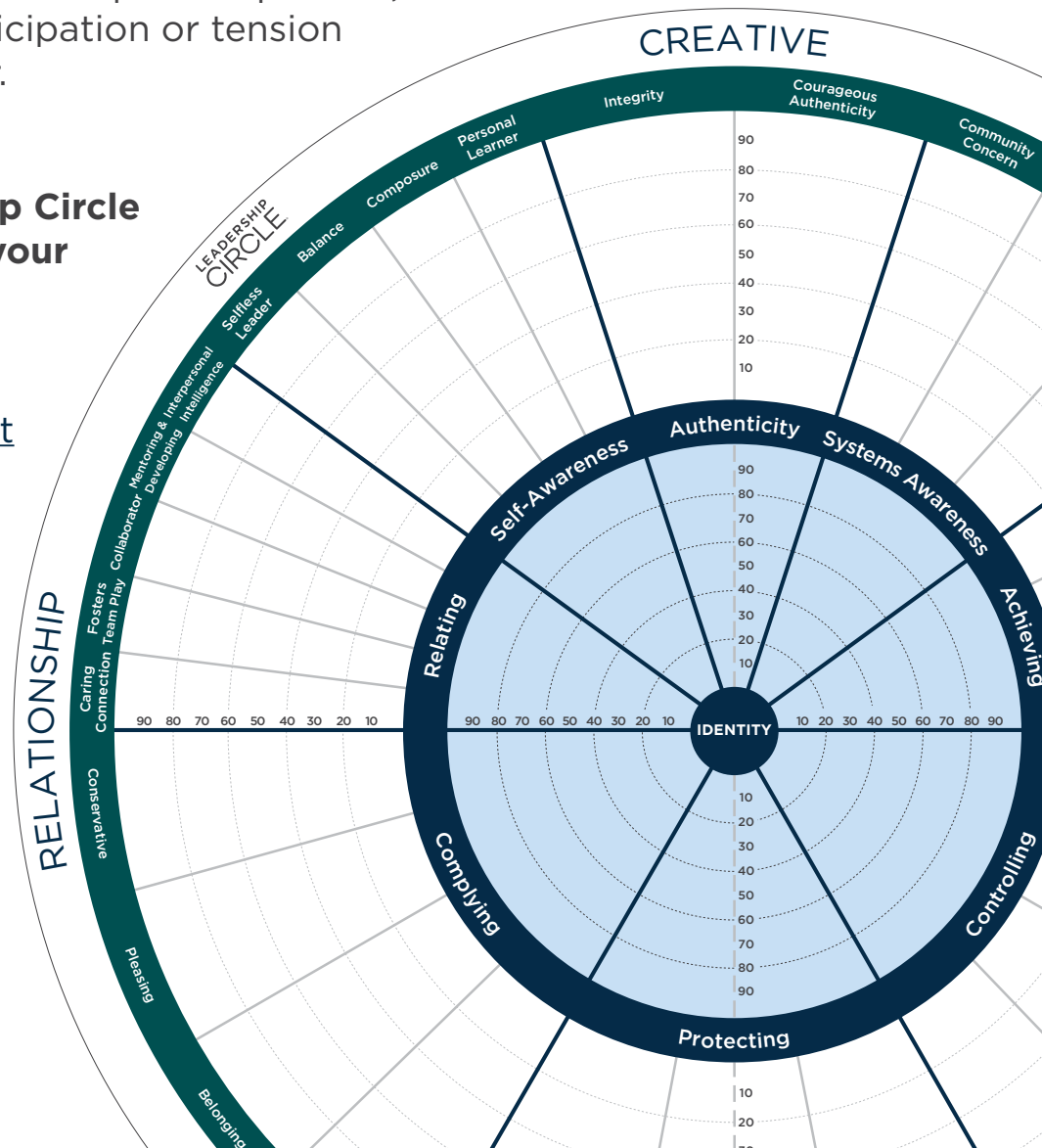



# LEADERSHIP CIRCLE **VIRTUAL MATS**

The Leadership Circle **VIRTUAL** Mat is the virtual counterpart to the physical Mat that has long been a favorite staple of Leadership Circle Coaches for teams. Like the physical Mat, the Virtual Mat helps participants interpret and internalize their LCP results on a higher level in a virtual team environment.

We now have two options for Virtual Mats to fit your needs as a coach. We invite you to use whichever works best for your practice.

## FREE VIRTUAL LCP MAT

Find the **FREE** Google Virtual Mat here: [\*\*FREE LCP MAT\*\*](#)

Feel free to use and modify as you like. **PLEASE MAKE YOUR OWN COPY.**

There is a “How To” video with tips and instructions at the top of slide 1.

Enjoy!

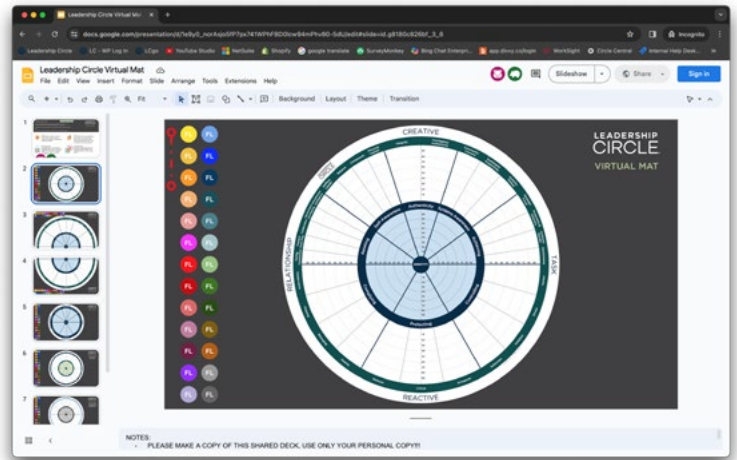

## PREMIUM MURAL MAT

We have a Premium Virtual Mat for Mural users. It includes additional mat graphics, is easier to use, and seamlessly works with all your preferred Mural facilitation techniques. Additionally, co-branding is included in the price as an option.

Please get in touch with our [\*\*Customer Support Team\*\*](#) for purchasing.

If co-branding, our Customer Support Team will request vector files of your logo and other branding assets.





# LEADERSHIP CIRCLE PHYSICAL MATS

LCP Manager Edition Mat

Collective Leadership Assessment Mat

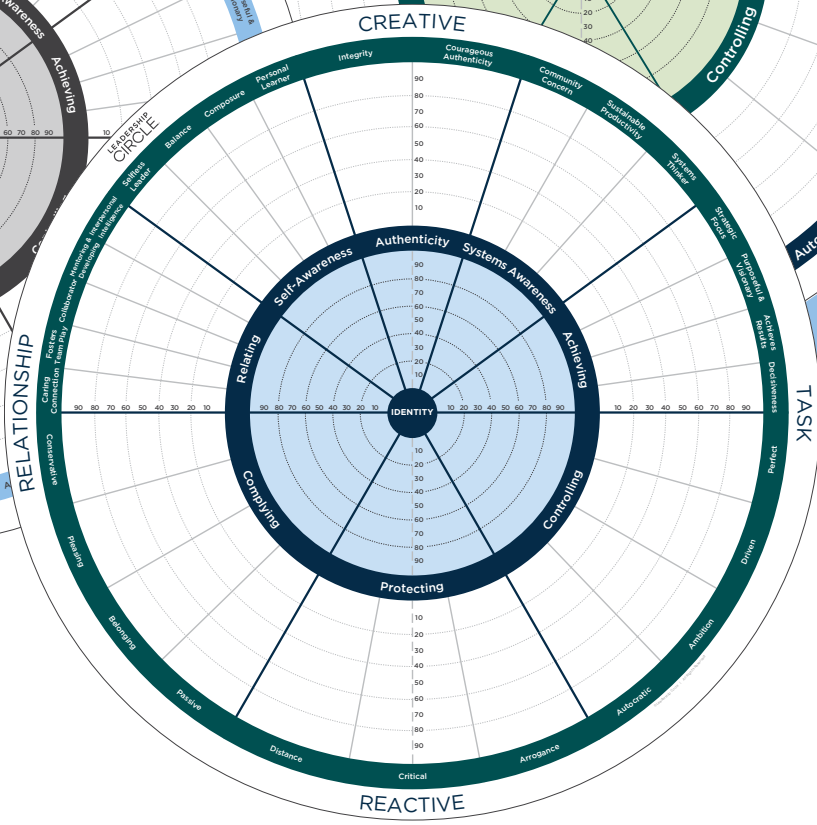
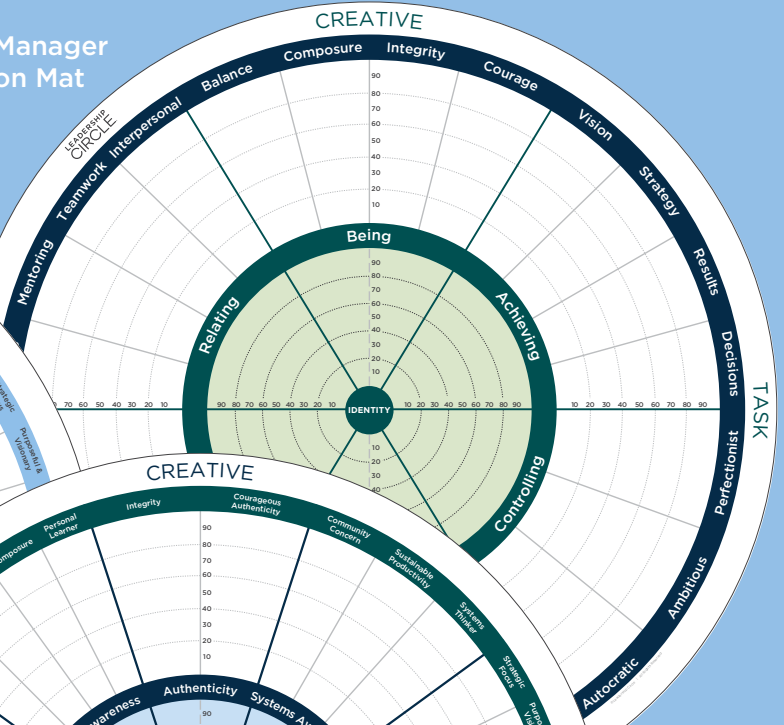
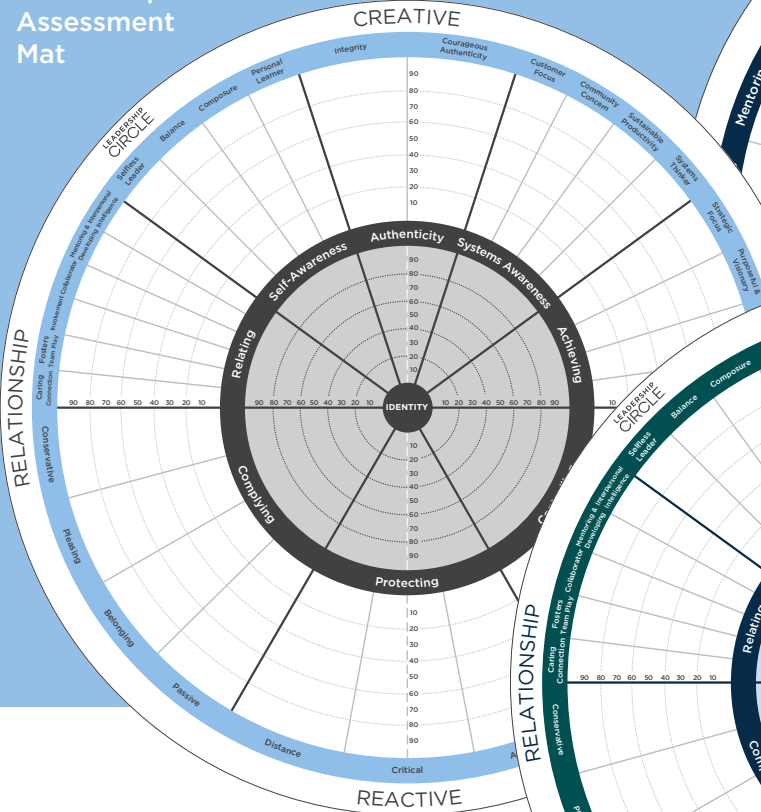

Leadership Circle Profile Mat

Each version of the Leadership Circle Mat comes in a variety of sizes to accommodate any group you may be working with.

Please get in touch with our **Customer Support Team** for purchasing.

**Mat Size\***

- 2 ft. / 0.6 m
- 5 ft. / 1.5 m
- 10 ft. / 3 m
- 15 ft. / 4.5 m
- 20 ft. / 6 m

**To Accommodate a group size of:**

- Tabletop
- 4 people comfortably; 6 max
- 8 people comfortably; 12 max
- 12 people comfortably; 15 max
- 20 people comfortably; 25 max

\*Larger sizes available upon request



# MAT EXERCISES

There are a myriad of Mat exercises and uses for coaching any size of group or team, see below for a few of our favorites.



**CELEBRATE YOUR STRENGTHS** - Have participants find and stand in their highest Creative extension. Using their Profile Interpretation Guide, ask them to have a conversation with those near them about the value that their highest extension brings to the organization they are helping to lead. Then ask each person/group in each competency to briefly teach the group about the value of that behavior.

**FIND YOUR PEOPLE** - Have participants go find their people on the Reactive side (controllers, protectors, compliers aggregating together). Participants go out one at a time and stay on the grid until all are in place. Now have them stand on the particular reactive stance that most typifies them or was most evident in their profile. Have them notice who is with them and who is in the other groups. Ask the group for any observations.

**GIFTS** - Start in Reactive stances; ask what the gift is there and if it were truly used consciously, intentionally and without compulsion/fear what would it become? Go to the place on the Creative that would be created (e.g., What happens when you put power in relating? What happens when you put vulnerability in authenticity? What happens when you put caring in achieving?). Stand in these new places; what do you have now? Controllers move to Achieving; what's different now? What's different between standing here and standing there? To get really good at results (alignment, motivation, vision, engagement), what has to be added?

**RISKS** - What is the feeling you get standing here in the Reactive? What is the risk you are managing? Get each group (controllers, protectors, compliers) to name the risk they are managing in that space. Underneath it all is vulnerability, the common ground we stand on is vulnerability, we all wear different armor but the ground is the same. I made a different deal: I'll outrun you, I'll outsmart you, I'll let you win. They are all deals to cover the vulnerability.

**BODY SCULPTURE** - Staying where they are, have the participants assume the posture associated with the Reactive space they are standing in. What non-verbal, purely physical, theatrical pose would most exemplify the Reactive stance they are in or on?



# MAT EXERCISES CONTINUED

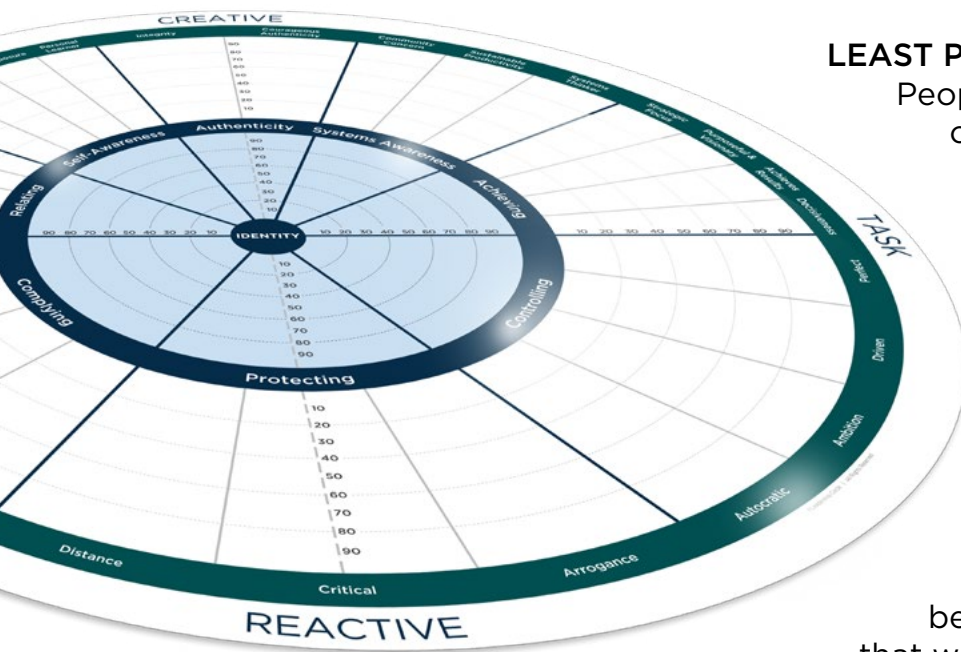

**LEAST PREFERRED** - Start with Find Your People, go to your least preferred place on the Reactive side (e.g., compliers going to controlling side). I have to be nice; it makes me feel safe/worthy/good. If I am over here and have to be mean I am unsafe/unworthy/bad.

**NAMES** - Have each group share what they call the other groups (wimp, hard ass, jerk, egghead, etc.), record these on three flip charts. Work the shadow side. I reject that because if I am that way or seen that way it means... What is the dynamic between high controlling and high complying?

**BLIND SPOTS** - Trade coaching summaries with your partner; identify the biggest congruence gap on your partner's summary on the Reactive side. Blindfold your partner, escort them to that spot on the TLC and leave them there for two minutes. Switch roles and do it again, then sit down and talk about the experience.

**DUELING VOICES** - To demonstrate the dynamics of the opposites in the profile, have a participant stand on the Identity circle in the center of the Mat. Ask them which Creative Competency is the one they would like to grow. Have another participant stand on that Creative spot. Ask the participant which Reactive Style might be getting in the way or sabotaging their best efforts. Have a third participant stand on that Reactive spot. Have the two outer circle participants begin to make statements in dueling voices about why it's better to head in their direction. The participant in the middle will begin to shift from the Identity Circle to each of the two voices as they get stronger or give more compelling "reasons" to come their way. Talk about the impact of pursuing a Creative vision versus the fear of staying safe in a Reactive stance.

**THE THREE REACTIVE DIMENSIONS\*** - Break the group into three subgroups standing behind the Reactive on the Mat. Assign each group to one Reactive Dimension, and ask them to flip-chart their answers to a couple of the following questions for their assigned Dimension:

1. What are we trying to accomplish when we are standing in Controlling/Protecting/Complying? What behaviors/strategies do we use to do that?

\*Shared by permission of Peggy McAllister, Internationalleadership.net



# MAT EXERCISES CONTINUED

2. What are our worst nightmares? What behaviors/strategies do we use to prevent these nightmares from happening?
3. What are the gifts we offer the organization from this dimension?

**STANDING ON MY OWN REACTIVE\*** - Ask for volunteers to come stand on their strongest Reactive tendency; the one they would like to explore further. One by one ask each to describe their own real life experience when they are acting from that Reactive strategy. Questions for them might include: What are some of the behaviors we might observe when you are standing in this Reactive place? What sorts of situations and people trigger this in you? What's at risk for you if you don't succeed with this strategy? Next, ask each to move to a Creative Strategy that would support their highest intentions / vision. Ask similar questions. Compare Creative & Reactive responses.

**BUSINESS ON THE MAT\*** - The team identifies a business issue that is keeping them all up at night. Each member of the team stands on the Reactive strategy on the Mat where they tend to stand when facing this issue. As each leader is asked to speak only from the one Reactive strategy of theirs, they all attempt to resolve the issue together. After 20 minutes or so, they all move to their own Creative competency of choice, and as a team, open up the conversation again from that perspective.

**JUST-IN-TIME TEAM DIALOGUE\*** - During a regular team meeting, when conflict, divisiveness, or old dysfunctional patterns arise, "take it out on the Mat." Pause the conversation, ask everyone to walk over to the Mat, and then ask each participant to stand on the Mat in the place from which they believe they had been operating. Pause and ask others to confirm or suggest another place on the Mat that best represents where they perceive that leader was actually operating from. Once they are all standing in that initial place on the Mat, ask the group to pick up the conversation again. Participants then move around the Mat to stand in the place that represents where they are speaking from in each moment. And then at some point if nothing in the dysfunctional pattern shifts, ask them all, "Where do you need to stand in order to move this conversation forward? Go stand there."

\*Shared by permission of Peggy McAllister, [InternationalLeadership.net](http://InternationalLeadership.net)



# MAT FOLDING INSTRUCTIONS

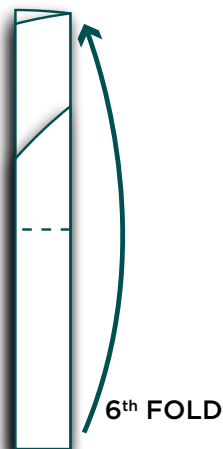
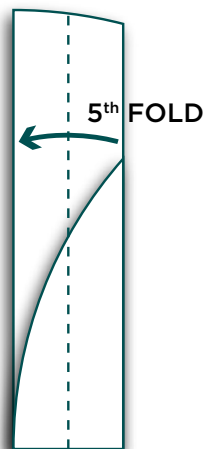
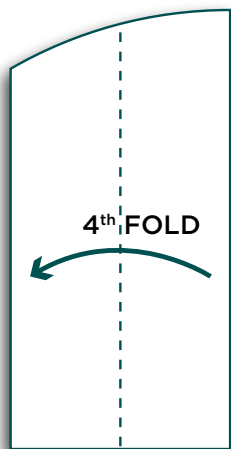
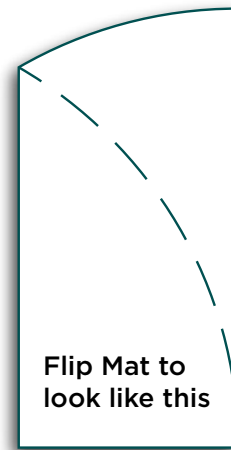
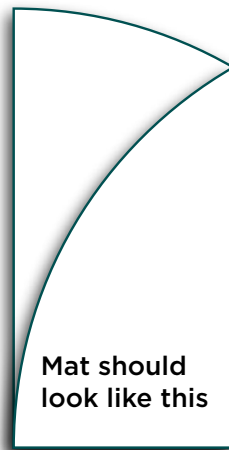
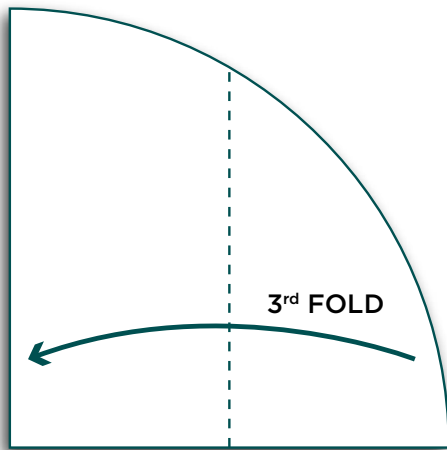
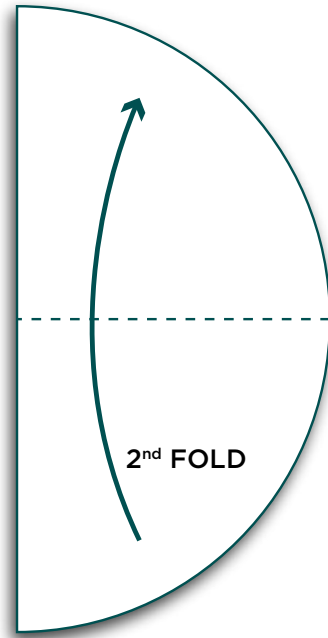
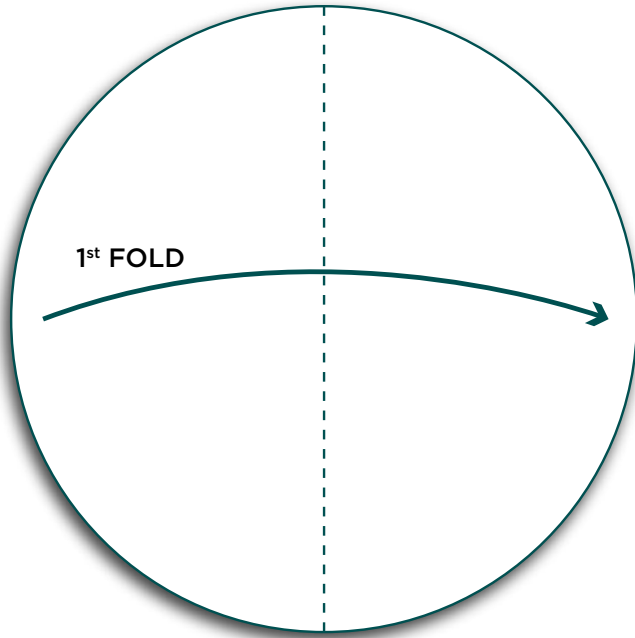

**7th FOLD:**  
In 1/3 or 1/2  
depending  
on fit in bag



OR



**BAG IT  
& DONE!**